



ARGUS SPECTRUM

STRELETZ-PRO

WIRELESS FIRE SYSTEM

200 000 installations
around the world





9 000 000 wireless
devices sold

Successfully passed tests
in **83** countries



about
the company



-  **About us** 3
-  **Certification** 4–5
- About the system** 6–7
- Features** 8–13
- System structure** 14–23
-  system structure of Streletz–PRO 14–15
- translator / expander 16
- fire detectors 17–18
- alarm devices 19–23
- input and output modules 23
- security detectors 24–25
-  **Case studies** 26–30
-  **Virtual classroom** 31



About Us

Argus Spectrum is one of the world’s leading manufacturers specialising in the development and production of innovative wireless and wired fire detection and security systems.

The company was founded in the city of St. Petersburg in 1993 by two leading scientists working in the field of experimental radio physics and electronics, operating within the faculty of Peter the Great Polytechnic University. Our products have a proven record of performance, quality, and reliability with more than 200,000 systems installed worldwide.

Certification

Argus Spectrum wireless fire solution complies with the fire regulations of 83 countries including the Russian Federation, EU, the UK, India, Dubai and Australia.

Research and Development

Our close collaboration with the specialist universities of St. Petersburg enables us to develop and apply state of the art technology within our product program. A continuous program of research and development is led by a team of 50 highly qualified engineers delivering a comprehensive range of products to our global partners. Argus Spectrum has been recognized and presented with 2 prestigious awards from the Government of the Russian Federation in the field of science and technology.

Production

We operate strict quality management systems in accordance with ISO 9001. We have been recognized by and awarded the Toyota Bronze Medal for our Production Management System.

Projects

Argus Spectrum products are protecting significant and high-profile installations including the world-famous Hermitage and the Medical Academy in St. Petersburg incorporating more than 20,000 wireless devices. In 2020–2021 more than 30 newly constructed COVID–19 hospitals all over Russia were protected by Argus Spectrum advanced wireless fire detection system. All the hospitals were built in record time while the first 17 of them were constructed within 60 days. More than 60,000 wireless devices were installed in the new medical centers.

The Stretz-PRO wireless fire alarm system successfully passed tests and complies with the fire regulations of 83 countries including the Russian Federation, EU, the UK, India, Dubai and Australia.

Argentina	Greece	Libya	Papua New Guinea	Switzerland
Armenia	Hong Kong	Lithuania	Philippines	Syria
Australia	Hungary	Malaysia	Poland	Taiwan
Austria	India	Malta	Portugal	Tajikstan
Azerbaijan	Indonesia	Marshall Islands	Qatar	Thailand
Bahrain	Iran	Micronesia	Russia	Tonga
Belarus	Iraq	Moldova	Samoa	Turkey
Brazil	Ireland	Mongolia	Saudi Arabia	Turkmenistan
Bulgaria	Israel	Nauru	Singapore	Tuvalu
Cyprus	Italy	Netherlands	Slovakia	UAE
Czech Republic	Jordan	New Zealand	Slovenia	Ukraine
Denmark	Kasakstan	Nigeria	Solomon Islands	United Kingdom
Egypt	Kashmir	Norway	South Africa	Uzbekistan
Fiji	Kenya	Oman	Spain	Vanuatu
Finland	Kiribati	Pakistan	Sri Lanka	Vietnam
Georgia	Kuwait	Palau	Sweden	Yemen
Gibraltar	Kyrgyzstan			

	Requirements / standards
EN 54-3	Fire alarm devices – Sounders
EN 54-5	Heat detectors – Point heat detectors
EN 54-7	Smoke detectors – Point smoke detectors using scattered light, transmitted light or ionization
EN 54-11	Manual call point
EN 54-17	Short circuit isolators
EN 54-18	Input/output devices
EN 54-23	Visual alarm devices
EN 54-25	Components using radio links
EN 54-29	Multi-sensor fire detectors – Point detectors using a combination of smoke and heat sensors
EN 301 489-1	ElectroMagnetic Compatibility (EMC) standard for radio equipment and services
EN 50130-4	Audio/Video, information and communication Technology Equipment – Part 1: Safety Requirements
2011/65/EC	RoSH directive including Directive (EU) 2015/863
	Dubai Civil Defense Approval
AS ISO 7240.3	Audible alarm devices
AS ISO 7240.5	Point type heat detectors
AS ISO 7240.7	Point type smoke detectors using scattered light, transmitted light or ionization
AS ISO 7240.11	Manual Call Points
AS ISO 7240.15	Point type fire detectors using scattered light, transmitted light or ionization sensors in combination with a heat sensor
AS ISO 7240.18	Input/output devices
AS ISO 7240.23	Visual alarm devices
AS ISO 7240.25	Components using radio transmission paths
TR EAEU 043/2017	Requirements for Fire safety and Fire Extinguishing Equipment



The Stretz-PRO product range is fully compliant to the technical regulations of the Eurasian Economic Union TR EAEU 043/2017 Requirements for Fire safety and Fire Extinguishing Equipment

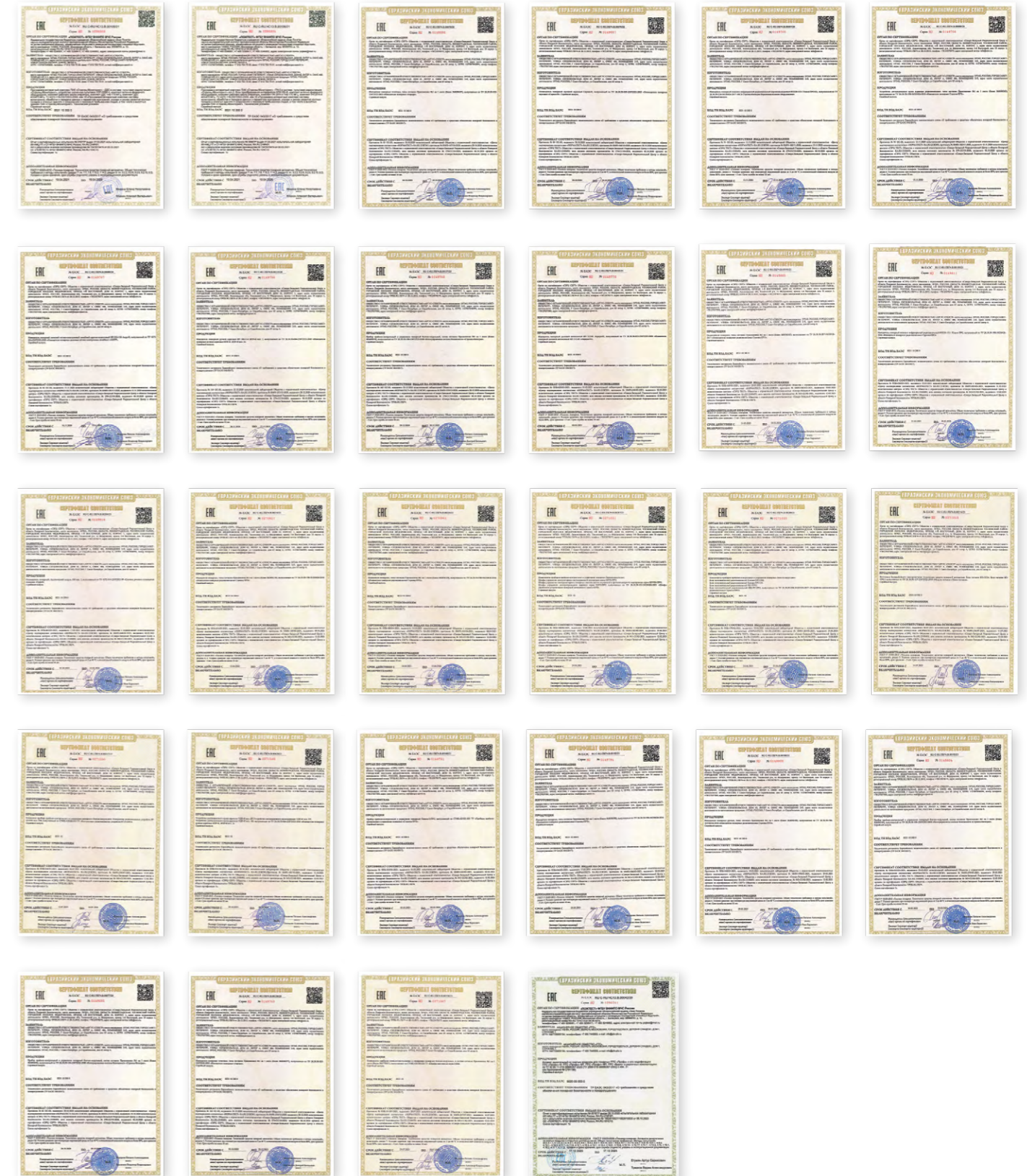



STRELETZ ^{PRO} - IS



Wired and wireless fire alarm system



Wired and wireless notification system

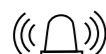

Wired and wireless security system



Personnel monitoring and alert system

SYSTEM ARCHITECTURE

- 2** orthogonal antennas
- 6** frequency channels
- 127** expanders
- 1920** devices

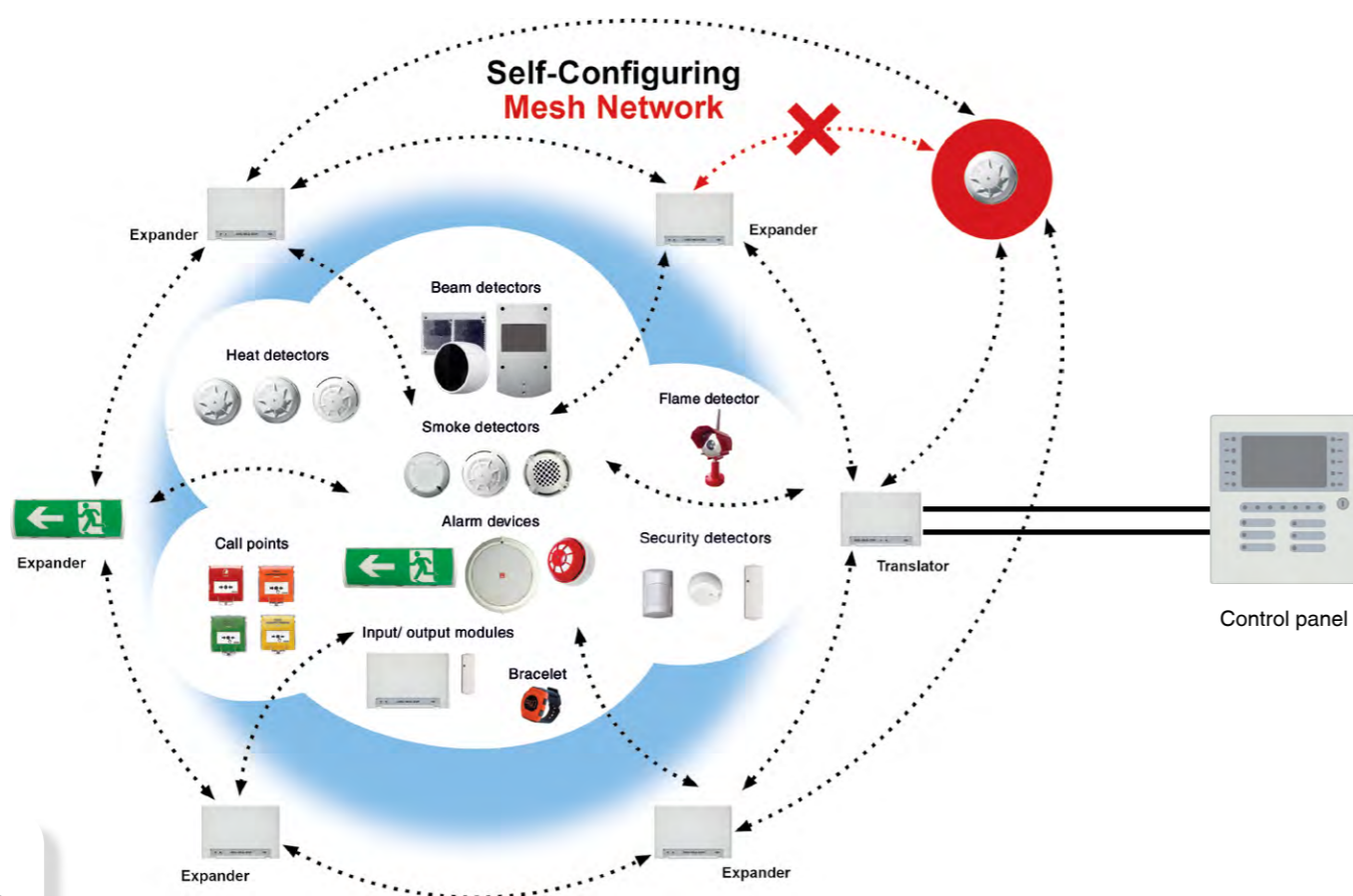

Translators and expanders

The translator module connects to the loop of a fire control panel, receives signals from wireless devices, and translates them to the panel. In order to expand the range of the network, expander modules are placed throughout the building. Signals from wireless devices can be received by the expanders, then travel through multiple expanders, eventually reaching the translator module.

Mesh network

Streletz-PRO supports the self-configuring mesh network technology, which means that detectors are not assigned to individual expanders, they choose their own parent expander, and all communication paths in the system are established automatically. The advantage of the mesh network is that you don't have to manually specify the network topology, you only need to position the expanders throughout the building based on their connection radius, and the network will automatically arrange itself in the most optimal way. This technology significantly speeds up the installation procedures.

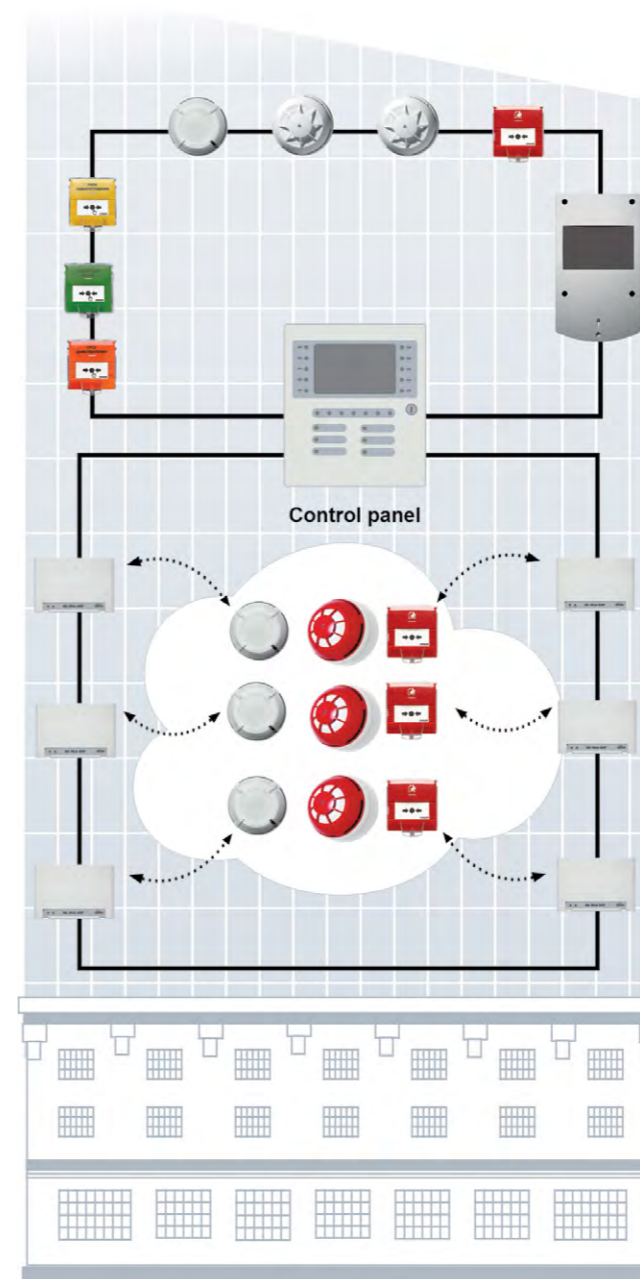

Wireless Intelligent

- Self-configuring mesh network
- 1920 wireless devices
- 10-year battery life
- 3 sec. alarm activation delay



about the system



Streletz-PRO advanced features

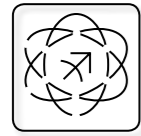

Mesh network

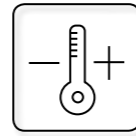

Wide operating temperature range

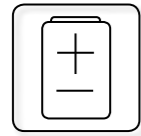

10 – year battery life



Cryptographic protection

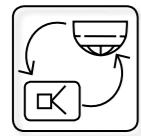

1 200 m – communication range

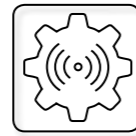

Changing settings wirelessly

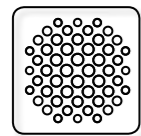

1 920 devices system capacity

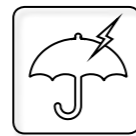

High level of noise immunity



3 – second activation delay



Cloud service

Mesh network

Self-configuring mesh network technology in Streletz-PRO is a new and unique level of reliability:

- each device automatically chooses its parent expander;
- expanders automatically form a network for delivering information to the main control panel.

Self-configuring mesh network technology provides:

- high level of reliability;
- automatically adapting to changing operating conditions: all devices automatically choose a parent expander depending on the quality of connection;
- extended information system capacity allowing complex issues to be managed and solved;
- a simple design and commissioning process;

The system will automatically decide which device connects to which expander and build a wireless network.

Advantages for installers:

- simplified design and planning process;
- faster commissioning process;
- solutions to complicated problems and challenges.

Automatic reconfiguration of communication routes

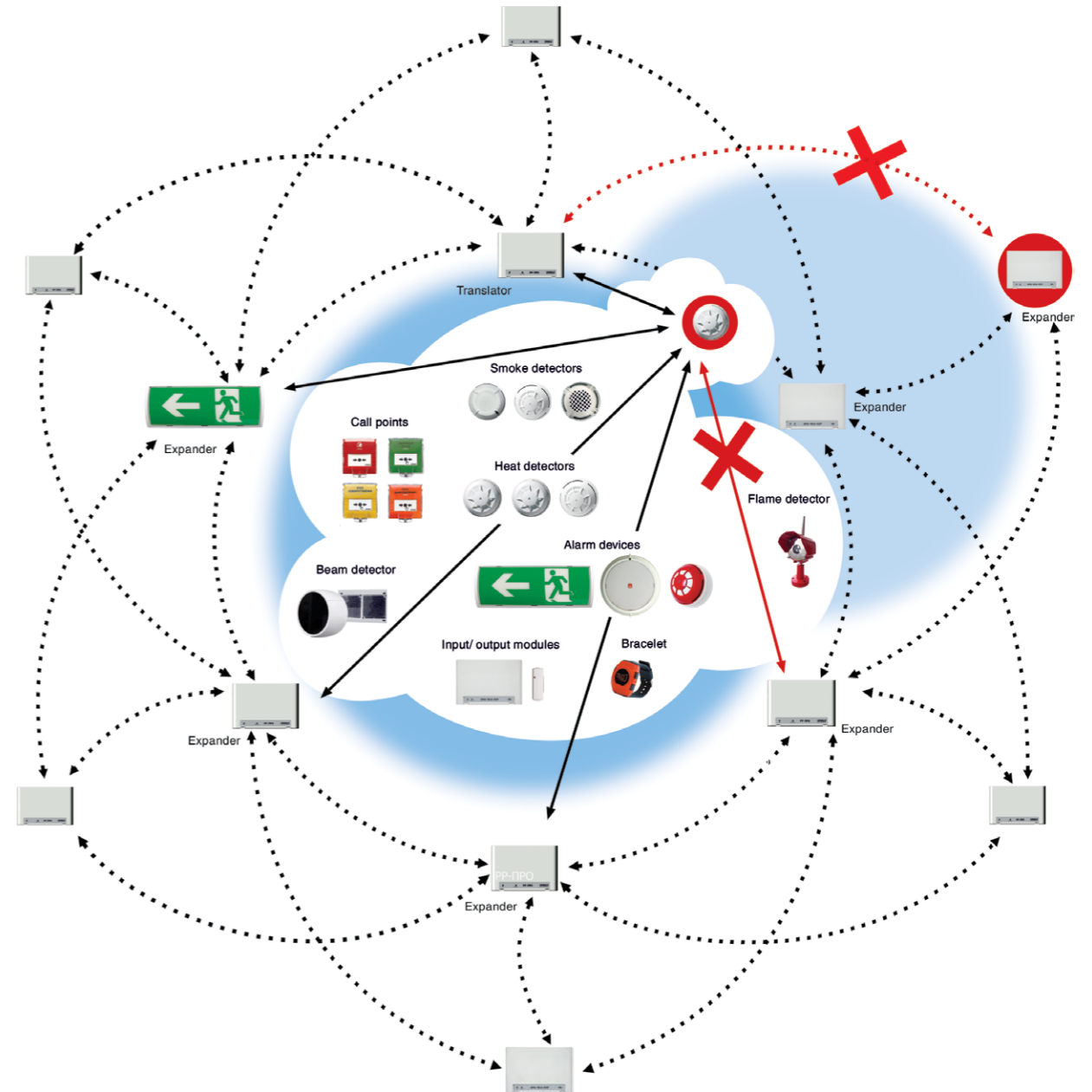

designing the Streletz-PRO network



Automatic reconfiguration of communication routes



Unavailable communication route

Shortest redundant route

10-year battery life

- Every device in the system monitors the state of its primary and backup battery and the Streletz-PRO software is designed to provide the user efficient and planned battery replacement.
- Signal delivery confirmation and automatic adjustments to transmission power.
- Software monitors the state of the batteries, which allows planning battery replacement ahead of time.

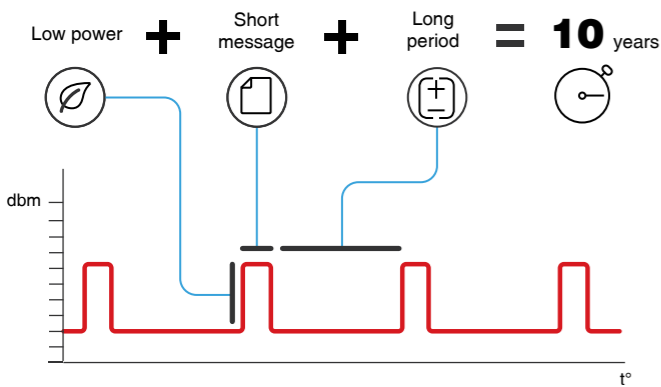

1920 devices

System capacity:

- 1920 wireless devices;
- 127 expanders;
- 512 zones

Up to 1920 wireless devices can be installed in a single radio network without mutual interference. Such a number of devices in Streletz-PRO allows to solve a more complex class of tasks and equip various types of objects.

3-second activation delay

All alarm notification devices activate in under 3 seconds. This ensures quick and safe evacuation from the building in the event of an emergency. The activation is synchronized.

1200 m – communication range

The maximum communication range in open space between expanders is 2,000 meters, between an expander and a child device is 1,200 meters. This is significantly higher than the communication range of most wireless fire detection systems on the market.

Wide operating temperature range

Streletz-PRO operates within a temperature range of -30 to +55 degrees. The system implements the principle of automatic frequency adjustment when the devices are in temperature modes.

Cryptographic protection

Streletz-PRO implements dynamic information encoding and dynamic two-way authentication mechanism to eliminate the possibility of tampering with the radio system

Changing settings wirelessly

All parameters of the system devices are programmable wirelessly.

High level of noise immunity

One of the most important parameters of any system is its level of resistance to external interference and electromagnetic interference.

Cable lines often serve as antennas for electromagnetic interference, and the resulting voltage in the conductors leads to false alarms.

The inducing voltage is proportional to the length of the conductor (in wired systems it is the cable length, in wireless systems it is the antenna length), which means that wireless detectors are virtually immune to the effects of inducing voltage.

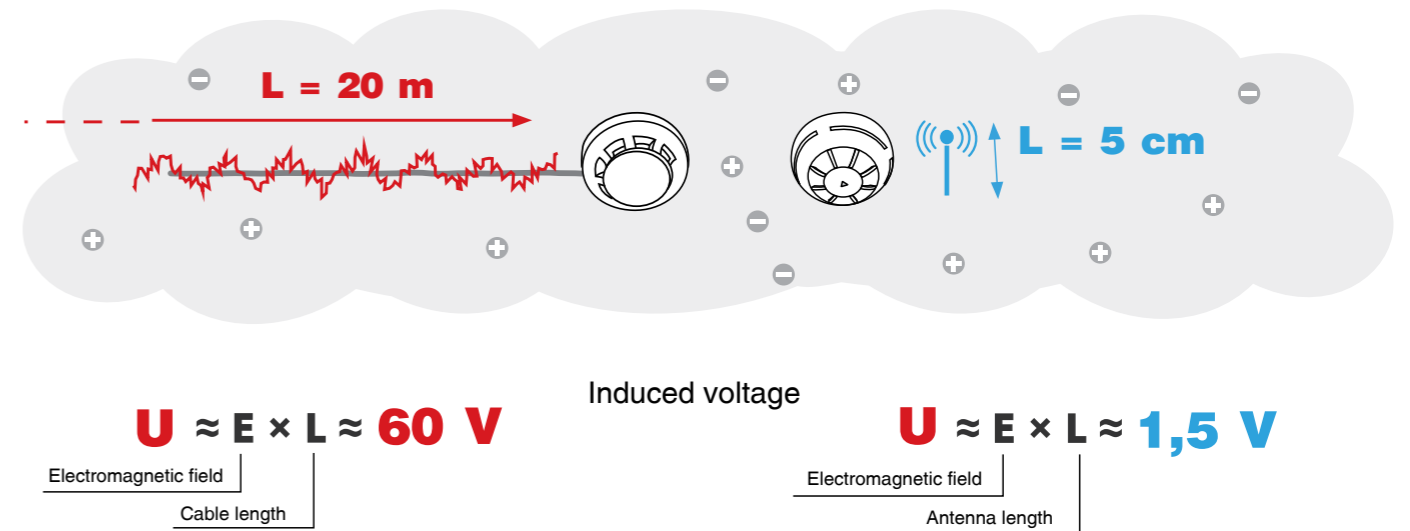

The system implements the following noise immunity algorithms:

- **Transmission period of the control signals is adjusted automatically.**
When in standby mode, the devices are communicated at long interval. However, in an emergency, the signal transmission period is shortened.
- **Transmission power is adjusted automatically.**
Under normal conditions, radio transmission signal power is reduced to conserve battery power. However, when exposed to interference, radio devices increase power to ensure signal delivery.
- **6 radio channels, the operating channel is switched automatically in case of background noise is present.**

STEP 1. T2 < T1 Signal period decreases

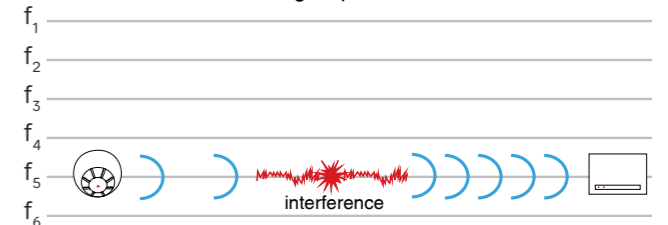

STEP 2. A2 > A1 Signal strength increases

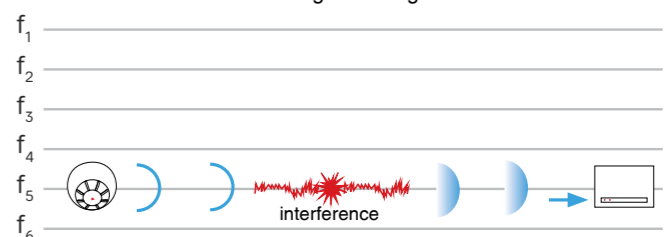

STEP 3. F2 ≠ F1 Changes the operating frequency channel

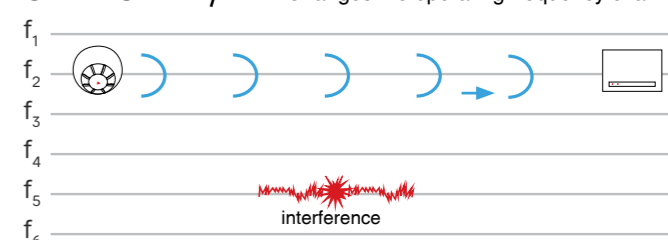

Cloud service

When discussing Argus Spectrum technologies, particular attention should be given to the Streletz-Cloud cloud service. The service provides access to installed systems for the servicing organization and other authorized personnel.

The Streletz-Cloud allows control and monitoring of the system from anywhere in the world with Internet access via WEB-client, a mobile application (for iOS and Android) and desktop software.

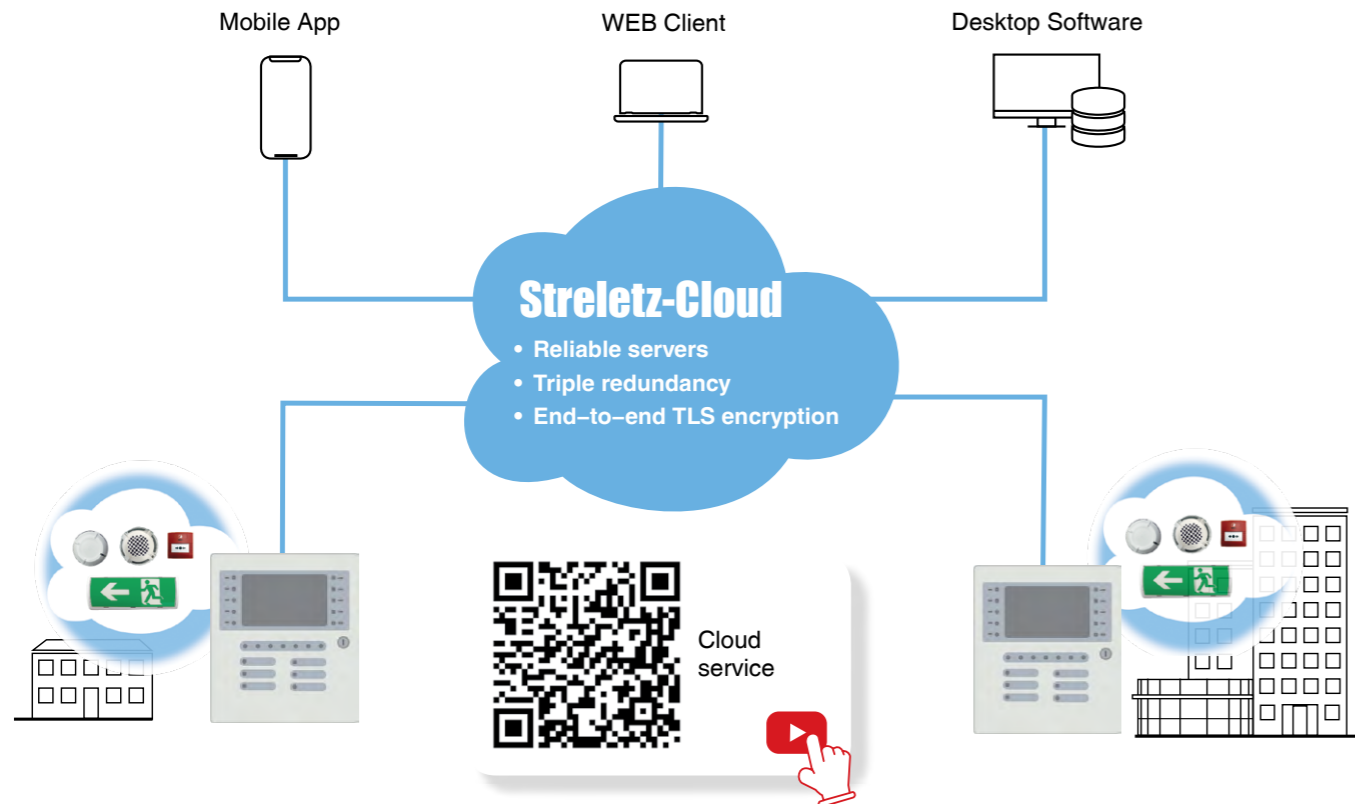

CONNECTING TO STRELETZ-CLOUD

Via web browser

The web client at **cloud.streletz.ru** allows you to monitor systems, view event logs and manage systems associated with the user account.

Via mobile application

The system app for iOS and Android has WEB client functionality in an interface adapted for smartphone screens. Events from all connected objects are sent in the form of push notifications, allowing the user to receive timely information about alarms and faults in the object.

Via software

The Streletz-Cloud can be used to connect to the system in desktop software. All functions of the system can be accessed remotely! Battery level, dust levels in detectors, quality of communication, changing settings and operating tactics, analysis and selection of event logs – all this and much more is available. The Streletz-Cloud can be accessed at any time and from any location.



FEATURES

Remote control

- view system status and event log;
- resetting fire alarms and faults;
- control of alarm devices.

All necessary control functions are available remotely for all connected systems.

Remote programming

No more on-site visits are required to make changes to the system configuration.

The Streletz-Cloud allows remote programming of the device parameters, changing the system algorithm, user lists and user access rights.

Protection against unauthorised access to the system – dual authentication: for access to the cloud service and for authorisation in the system.

Technical monitoring:

- dust level;
- power supply voltage;
- system faults.

Remote monitoring of the technical condition of the system enables maintenance to be planned in advance and ensures a rapid response to any faults.

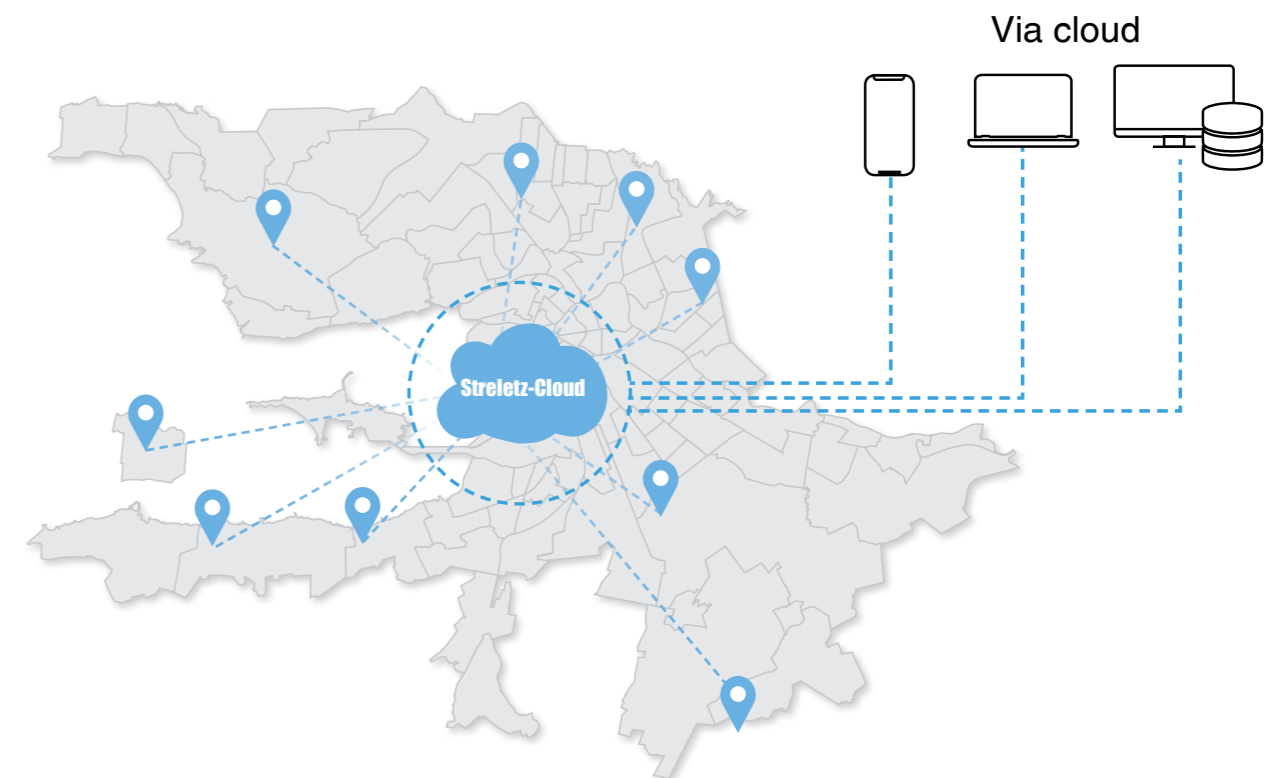

SERVICE INFORMATION SECURITY

Data transmission over the internet is protected by end-to-end encryption. Fault tolerance of the Streletz-Cloud service is ensured by triple hot and cold redundancy.

Information systems standards ISO 27001, ISO 27017 AND ISO 27018





Wireless Intelligent Addressable

TRANSLATOR / EXPANDER MODULES		ALARM DEVICES	
	ARG-WL8-TRV – wireless translator module		ARG-WL8-OS – wireless optical smoke detector with built-in sounder
	ARG-WL8-EXP – wireless expander module		ARG-WL8-HS – wireless heat detector with built-in sounder
	ARG-WL8-EXPN – wireless fire exit sign with built-in expander		ARG-WL8-OV – wireless optical smoke detector with built-in voice alarm speaker and visual alarm device
FIRE DETECTORS			ARG-WL8-SND – wireless sounder
	ARG-WL8-O – wireless optical smoke detector		ARG-WL8-V – wireless voice alarm speaker
	ARG-WL8-H – wireless heat detector		ARG-WL8-N – wireless exit sign
	ARG-WL8-OH – wireless combined sensor detector		ARG-WL8-PNBD – wireless personal notification bracelet (with display/without charger and GPS)
	ARG-WL8-B – wireless optical beam detector	MANUAL CALL POINTS	
	ARG-WL8-B1 – wireless optical beam detector		ARG-WL8-CP – wireless manual call point (red)
	ARG-WL8-FL – wireless flame detector ARG-WL8Ex-FL – wireless intrinsically safe flame detector		ARG-WL8-CP – wireless manual call point (green)
	ARG-WL8-FL – wireless flame detector ARG-WL8Ex-FL – wireless intrinsically safe flame detector		ARG-WL8-CP – wireless manual call point (orange)
	ARG-WL8-FL – wireless flame detector ARG-WL8Ex-FL – wireless intrinsically safe flame detector		ARG-WL8-CP – wireless manual call point (yellow)
SECURITY DETECTORS		INPUT / OUTPUT MODULES	
	Arfa-PRO – wireless acoustic glass break detector		ARG-WL8-IN – wireless single input module
	Ikar-PRO – wireless passive infrared detector		ARG-WL8-OUT – wireless single output module
	ARG-WL8-IN – wireless input module and magnetic detector		
	Metka-PRO – wireless inertial sensor		
	Gradus-PRO – wireless temperature sensor / Voda-PRO – wireless water leak sensor		
	Brelok – PRO – wireless key fob		

Wired Intelligent Addressable

FIRE DETECTORS		INPUT / OUTPUT MODULES	
	Aurora-DI v.2 – intelligent optical smoke detector with short-circuit isolator		MV1-I – intelligent single input module
	Aurora-TI v.2 – intelligent heat detector with short-circuit isolator		IB1-I – intelligent single relay module
	Aurora-DTI v.2 – intelligent multi-sensor detector with short-circuit isolator	ANCILLARY	
	Strengthened base – intelligent detectors base		ARG-FWR – firmware programming tool
	Amur-I – intelligent optical beam detector		Aurora-3P – handheld programming unit
	Amur-I – intelligent optical beam detector		ZU-1 – individual charging device for ARG-WL8-PNBD
ALARM DEVICE			Puller Aurora – puller for the point detectors
	Sirena-I – sounder		Reflector unit – reflector unit for ARG-WL8-B, Amur-I
MANUAL CALL POINTS			Bracket unit – bracket unit for ARG-WL8-B, Amur-I
	IPR-I – intelligent manual call point (red)		BP-12/2A – power supply unit
	IPR-I – intelligent manual call point (green)		
	IPR-I – intelligent manual call point (orange)		
	IPR-I – intelligent manual call point (yellow)		

ARG-WL8-TRV
Wireless translator module



The translator module allows fully intelligent and seamless integration of the wireless devices alongside standard wired devices

FEATURES:

- Loop powered
- Dynamic routing for all expanders and field devices
- Bi-directional wireless communication
- Capable of linking up to 240 fully intelligent wireless field devices
- Supports full device intelligence
- Operating temperature range: -30 °C to +55 °C

ARG-WL8-EXP
Wireless expander module

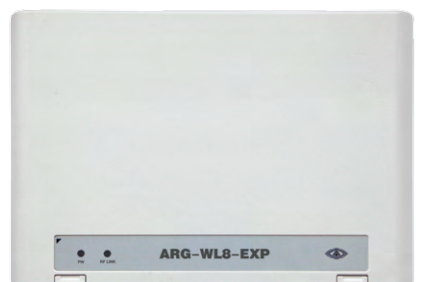

The wireless expander module provides a convenient method to increase radiocommunication range beyond that possible from a single translator by relaying the radio communication to further expanders or directly to the wireless field devices.

FEATURES:

- Dynamic routing for all expanders and field devices
- Bi-directional wireless communication
- Capable of linking up to 240 fully intelligent wireless field devices
- Supports full device intelligence
- 2 built-in inputs/outputs
- Operating temperature range: -30 °C to +55 °C

ARG-WL8-EXPN

Wireless fire exit sign with built-in expander



The wireless expander with notification device is an output device which is activated in case of fire or emergency situations. The wireless expander with notification device is a device that has two main uses:

Expand the area coverage of a wireless system. Operate the same way as wireless expander module ARF-WL8-EXP.

Internally illuminated exit signs (direction LEFT, direction RIGHT, EXIT and other signs).

FEATURES:

- Dynamic routing for all expanders and field devices
- Bi-directional wireless communication
- Capable of linking up to 240 fully intelligent wireless field devices
- Supports full device intelligence
- Contains a built-in rechargeable Li-ion battery
- Operating temperature range: -30 °C to +55 °C

ARG-WL8-O
Wireless optical smoke detector



The wireless optical smoke detector samples the air in the protected area to provide the earliest warning of fire and yet offers a high level of false alarm rejection.

FEATURES:

- Adjustable sensitivity – low, normal or high
- Bi-directional wireless communication
- Fully intelligent
- 10-year battery life
- Self-optimizing wireless frequency and amplitude algorithms
- Patented design of smoke inlet to optical chamber
- Operating temperature range: -30 °C to +55 °C

ARG-WL8-H
Wireless heat detector



The wireless heat detector continuously samples the temperature in the protected area to provide the earliest warning of fire. The device is capable of being configured on site either in fixed temperature or rate of rise modes.

FEATURES:

- Rate of rise or fixed temperature mode
- Bi-directional wireless communication
- Fully intelligent
- 10-year battery life
- Self-optimizing wireless frequency and amplitude algorithms
- Operating temperature range: -30 °C to +55 °C

ARG-WL8-OH
Wireless combined sensor detector



The wireless multi criteria detector combines both smoke detection and heat detection technologies.

FEATURES:

- Combined heat and smoke sensing
- Bi-directional wireless communication
- Fully intelligent
- 10-year battery life
- Self-optimizing wireless frequency and amplitude algorithms
- Operating temperature range: -30 °C to +55 °C



ARG-WL8-B
ARG-WL8-B1

Wireless optical beam detectors



The wireless reflected type optical beam detector samples the air in the protected area. When smoke level between the unit and the reflector reaches the threshold the alarm is activated.

FEATURES:

- Built-in laser pointer for visual control during the tuning process
- Bi-directional wireless communication
- Fully intelligent
- 10-year battery life
- Operation range from 5 to 80 meters
- Operation range from 5 to 100 meters (ARG-WL8-B1)
- Operating temperature range: -30 °C to +55 °C

ARG-WL8-FL

Wireless flame detector



The wireless flame detector monitors the protected area and provides early detection of an open fire.

FEATURES:

- Bi-directional wireless communication
- Fully intelligent
- Operation range 25 meters
- Two built-in IR sensors
- 7-year battery life
- IP65 rating
- Operating temperature range: -30 °C to +55 °C

ARG-WL8-CP

Wireless manual call point



The wireless manual call point has a resettable plastic element, which displays a drop down warning flag when operated. A key is supplied with the MCP for reset and case opening.

FEATURES:

- Resettable element
- Bi-directional wireless communication
- Fully intelligent
- 10-year battery life
- Self-optimizing wireless frequency and amplitude algorithms
- Operating temperature range: -30 °C to +55 °C



ARG-WL8-OS

Wireless optical smoke detector with built-in sounder



The wireless optical smoke detector with built-in sounder samples the air in the protected area to provide the earliest warning of fire and yet offers a high level of false alarm rejection. Built-in sounder provides notification in case of fire.

FEATURES:

- Adjustable sensitivity – low, normal or high
- Bi-directional wireless communication
- Fully intelligent
- Sound synchronization with other sounders
- 10-year battery life
- Self-optimizing wireless frequency and amplitude algorithms
- Patented design of smoke inlet to optical chamber
- Operating temperature range: -30 °C to +55 °C

ARG-WL8-HS

Wireless heat detector with built-in sounder



The wireless heat detector with built-in sounder continuously samples the temperature in the protected area to provide the earliest warning of fire. The device is capable of being configured on site either in fixed temperature or rate of rise. Built-in sounder provides notification in case of fire.

FEATURES:

- Rate of rise or fixed temperature mode
- Bi-directional wireless communication
- Fully intelligent
- Sound synchronization with other sounders
- 10-year battery life
- Self-optimizing wireless frequency and amplitude algorithms
- Operating temperature range: -30 °C to +55 °C

ARG-WL8-OV

Wireless optical smoke detector with built-in voice alarm speaker



The wireless optical smoke detector with built-in voice alarm speaker samples the air in the protected area to provide the earliest warning of fire and yet offers a high level of false alarm rejection. The detectors provide white noise and strobe lights to indicate safe exit route.

FEATURES:

- Wireless evacuation system
- Adjustable sensitivity – low, normal or high
- Bi-directional wireless communication
- Fully intelligent
- Voice synchronization with other alarm speaker
- 10-year battery life
- Self-optimizing wireless frequency and amplitude algorithms
- Patented design of a smoke inlet to optical chamber
- Operating temperature range: -30 °C to +55 °C

Wireless channel is fire resistant

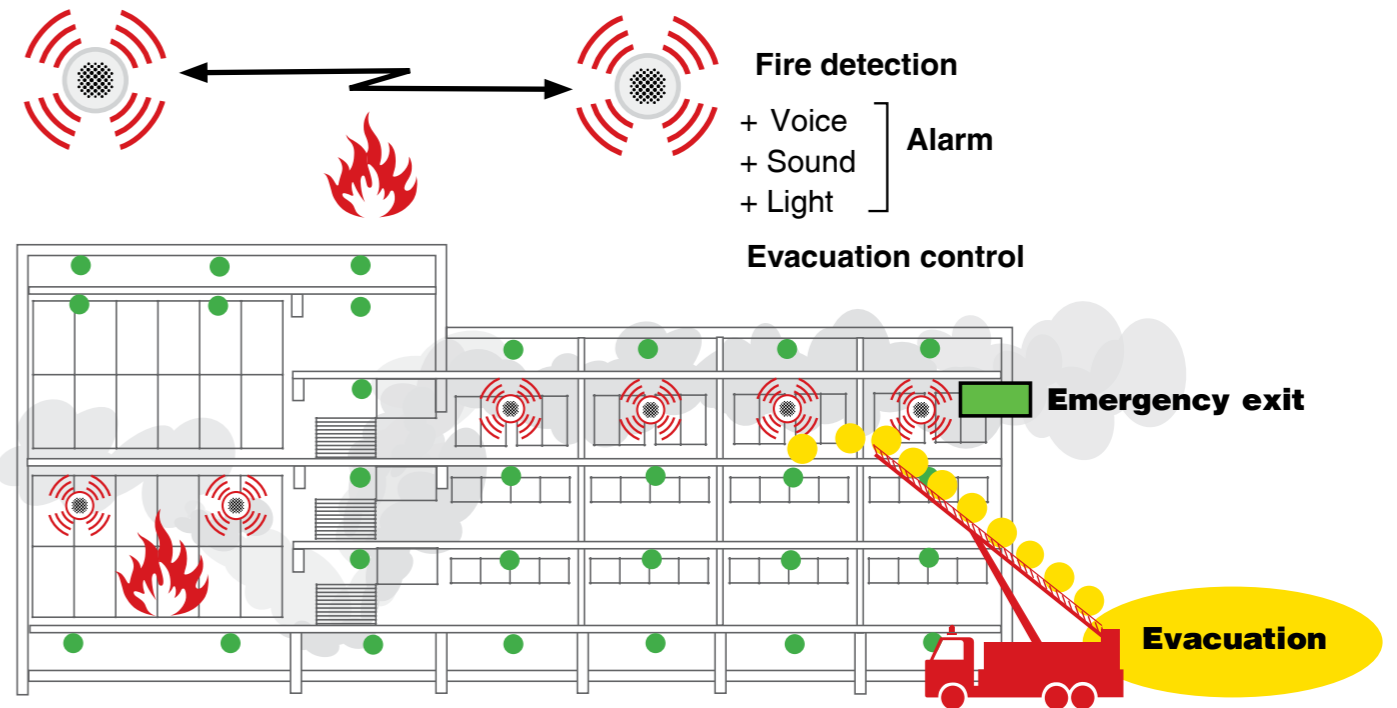

EXIT White noise and strobe lights indicate safe exit route

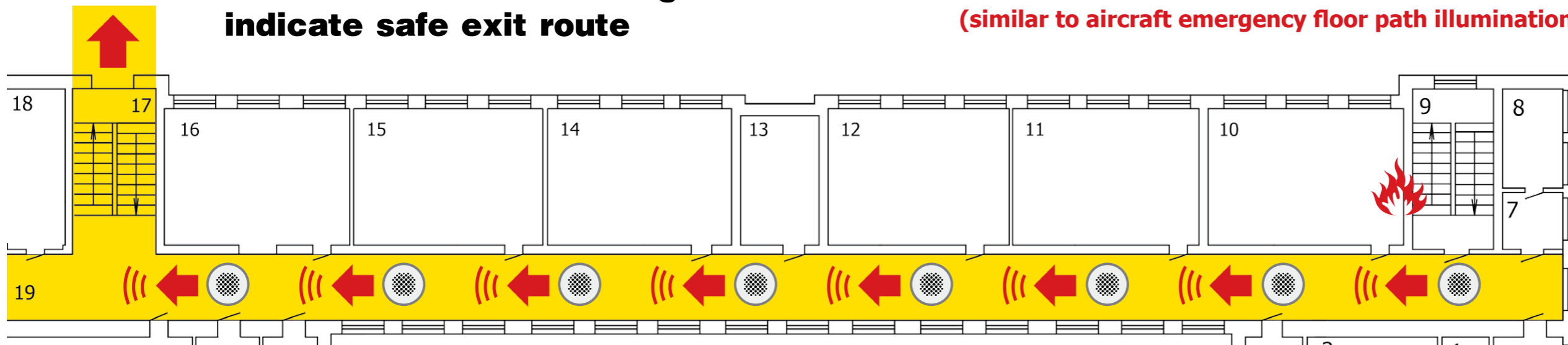

Wireless directional evacuation via sound and strobe lights (similar to aircraft emergency floor path illumination)



directional evacuation



solution for disabled people



1 Smoke detection in the protected area

Integrated fire detectors & voice alarm speakers analyze the smoke level in the air and transmit this information to the control device

2 Voice alarm about fire

In case of fire voice alarm speakers / detectors ARG-WL8-OV activate a synchronised voice message «attention there is a fire in the building – follow the sound and light indications»

3 «White noise» & strobe lights path

ARG-WL8-OV devices alternately flash the high intensity LED's and generate white noise to clearly indicate a directional path to the safest evacuation route

4 Control of evacuation

The system allows a change to the direction of sound wave and strobe lights path to alternate emergency exit routes if necessary



ARG-WL8-SND

Wireless sounder



The wireless sounder is fully addressable and benefit from an extensive range of intelligent control, test and monitoring functionality.

FEATURES:

- Sound synchronization with other sounders
- Bi-directional wireless communication
- Fully intelligent
- Sound pressure level 98 dB
- 10-year battery life
- Self-optimizing wireless frequency and amplitude algorithms
- Operating temperature range: -30 °C to +55 °C



ARG-WL8-V

Wireless voice alarm speaker

The wireless voice alarm speaker is fully addressable and benefits from an extensive range of intelligent control, test and monitoring functionality.

FEATURES:

- Voice synchronization with other alarm devices
- Bi-directional wireless communication
- Fully intelligent
- Voice pressure level 92 dB
- 10-year battery life
- Self-optimizing wireless frequency and amplitude algorithms
- Operating temperature range: -30 °C to +55 °C



ARG-WL8-N

Wireless exit sign

The wireless exit sign is internally illuminated escape signs (direction LEFT, direction RIGHT, EXIT and other signs) activated in emergency situations

FEATURES:

- Dynamic routing for all expanders and field devices
- Bi-directional wireless communication
- Fully intelligent
- 10-year battery life
- Operating temperature range: -30 °C to +55 °C



ARG-WL8-PNBD

Wireless personal notification bracelet

The wireless personal notification bracelet work as a personal notifiator as well as alarm button in case of emergency

FEATURES:

- Indoor and outdoor positioning
- Staff performance monitoring
- Occupational safety
- Bi-directional wireless communication
- Fully intelligent
- LED display
- Contains a built-in rechargeable Li-ion battery
- Operating temperature range: -10 °C to +55 °C



ARG-WL8-OUT

Wireless single output module

The wireless output module has been designed to allow control of a variety of equipment including access control doors, ventilation plant and fire extinguishing systems.

FEATURES:

- Activation synchronization with other modules
- Bi-directional wireless communication
- Fully intelligent
- 10-year battery life
- Self-optimizing wireless frequency and amplitude algorithms
- Operating temperature range: -30 °C to +55 °C



ARG-WL8-IN

Wireless single input module

The wireless input module is used for monitoring one input circuit and sending information to the control panel

FEATURES:

- Programmable input for fire and security detectors, emergency button or specialized detectors
- Bi-directional wireless communication
- Fully intelligent
- 10-year battery life
- Self-optimizing wireless frequency and amplitude algorithms
- Operating temperature range: -30 °C to +55 °C





ARFA-PRO

Wireless acoustic glass break detector



The wireless acoustic glassbreak detector detects if a pane of glass (window, door, glass case etc.) is shattered or broken, and sends information to the control panel.

FEATURES:

- Detects breakage of any type of glass
- Bi-directional wireless communication
- 10-year battery life
- Self-optimizing wireless frequency and amplitude algorithms
- Operating temperature range: -20 °C to +55 °C

IKAR-PRO

Wireless passive infrared detector



The wireless passive infrared detector detects motion in the protected area and sends information to the control panel

FEATURES:

- Detects motion up to 12 meters away
- Immune to pets under 20 kg.
- Bi-directional wireless communication
- 10-year battery life
- Self-optimizing wireless frequency and amplitude algorithms
- Operating temperature range: -30 °C to +55 °C

ARG-WL8-IN

Wireless input module and magnetic detector



The wireless input module and magnetic detector detects a forced entry into protected premises through doors and windows and/or monitors one input circuit and sends information to the control panel

FEATURES:

- Programmable input for fire and security detectors, emergency button or specialized detectors
- Bi-directional wireless communication
- 10-year battery life
- Self-optimizing wireless frequency and amplitude algorithms
- Operating temperature range: -30 °C to +55 °C

METKA-PRO

Wireless inertial sensor



The wireless inertial sensor used for detecting movement of objects and sending information to the control panel

FEATURES:

- Programmable sensitivity
- Compact size – 78x26x41 mm
- Built-in reed switch
- Can be used as a panic button
- Bi-directional wireless communication
- Self-optimizing wireless frequency and amplitude algorithms
- Operating temperature range: -10 °C to +55 °C

VODA-PRO

Wireless water leak detector



The wireless water leak detector is used for monitoring water leakage and sending information to the control panel

FEATURES:

- Open and short-circuit wire monitoring
- Programmable «response period»
- Bi-directional wireless communication
- 10-year battery life
- Self-optimizing wireless frequency and amplitude algorithms
- Operating temperature range: -30 °C to +55 °C

GRADUS-PRO

Wireless temperature detector



The wireless temperature detector is used for temperature monitoring and sending information to the control panel

FEATURES:

- Selectable upper lower and temperature threshold from -40 to +100 °C
- Bi-directional wireless communication
- 10-year battery life
- Self-optimizing wireless frequency and amplitude algorithms
- Operating temperature range: -30 °C to +55 °C

BRELOK-PRO

Wireless key fob



The wireless key fob is used to quickly arm and disarm the panel and perform other functions such as panic etc.

- 4 buttons, 12 combinations of clicks
- Bi-directional wireless communication
- Self-optimizing wireless frequency and amplitude algorithms
- Operating temperature range: -10 °C to +55 °C

30 new COVID-19 hospitals are protected by **Streletz-PRO**

In 2020 in the fight against COVID-19 the Russian Government ordered the fast track construction of new hospitals to be built all over the country. It is mandatory for these buildings to be equipped with reliable and proven fire detection systems.

Argus Spectrum International has been chosen to provide more than 30 newly constructed hospitals with the Streletz-PRO advanced wireless fire detection system.



60 000 wireless devices were installed and commissioned in the **30** new medical centers!



All the hospitals were built in record time while the first 17 of them were constructed within 60 days

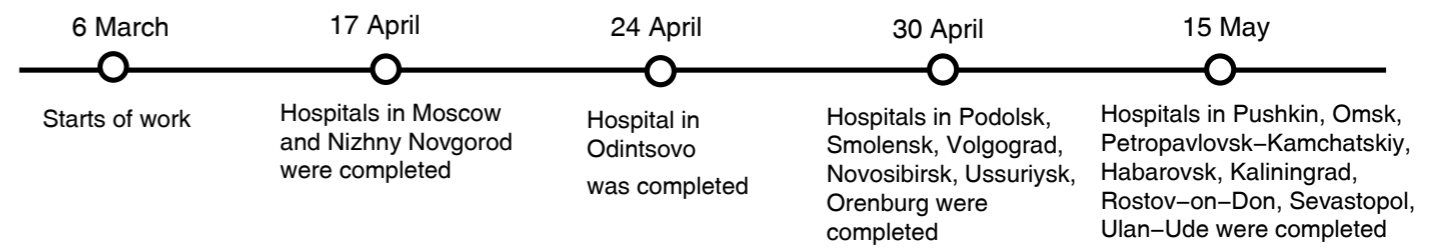

17 hospitals **200 000** m² – total area **2 500** – beds for patients

Why Streletz-PRO?

The advanced wireless technology is economical and installed approximately 5 times faster than a traditional wired system. This is made possible due to the self-configuring mesh network of Streletz-PRO providing comprehensive building protection comprising wireless: fire detection, notification, evacuation, automatic signaling to fire brigades, full system monitoring.

Wired system

1. Extensive period of installation
2. Expensive cabling installed by a team of qualified electricians
3. Frequent site visits for monitoring installation progress
4. Close integration with other services – construction, mechanical

Wireless system

Streletz-PRO

1. Rapid installation speed – approximately 5 times faster!
2. Minimal disturbance to the building
3. No requirement for expensive fire-resistant cabling
4. Remote configuration and monitoring



Medical Academy in Saint Petersburg



Project size:
summary square – 140,000 m²
20,000 detectors

Market sector:
medical, educational and scientific institution

System type:
hybrid wireless and wired

Project description

The multidisciplinary clinic of the Medical Academy represents a modern complex and consists of 7 buildings forming a single whole. The object includes clinical and diagnostic blocks, radionuclide Diagnostic block, educational and scientific blocks. The clinic required a fire detection and security alarm system.

Reasons for wireless use

The specificity of the hospital complex implies difficult access to individual rooms (surgery, resuscitation, etc.) and the need to maintain clean rooms.

Due to wireless technology the system was installed in a short time. Some parts of the system were pre-programmed and configured before they were installed in place for final testing and commissioning. In addition, the wireless system allowed to use wearable bracelets in the system for patients. The bracelets provide personal notification in case of fire alarms and perform the functions of a panic button. Wearable devices also automatically transmit alert to nurse's post in case of person's loss of consciousness.

Schools and kindergartens in Moscow



Project size:
– 150 schools and kindergartens in Moscow
– 40,000 wireless devices

Market sector:
educational institution

System type:
wireless

Project description

Educational institutions operating in the city of Moscow

Reasons for wireless use

The fire alarm systems of a large number of facilities had to be modernized in a short period of time without affecting the teaching process.

In 2019, a project was implemented in schools and kindergartens in Moscow to upgrade fire protection systems without decommissioning facilities. In 6 months, 150 children's educational institutions were equipped with new fire protection and remote monitoring systems.

Vnukovo air traffic control center in Moscow



Project size:
building area – 30,000 m²

Market sector:
transport

System type:
hybrid wireless and wired

Project description

The construction of new Vnukovo air traffic control center in Moscow started in 2009 and its handover for commissioning was in 2014. It is a three-storeyed building. The center is the largest air traffic control center in Europe. It controls the flights from 14 civil and 21 military aerodromes.

Reasons for wireless use

The challenge was to provide a flexible system that can be installed in a short time across the building, preventing disturbance to the occupants. Only wireless technology provides quick, easy and cost-effective installation (wireless communication between all the devices of the system). Wireless technology is now widely accepted as being as reliable and robust as traditional wired alternatives, yet offering much more in terms of flexibility, making Streletz-PRO an ideal choice.

Since the new system was planned beforehand, installation and handover went smoothly within the planned timescale. Finally, there were installed more than 1,000 wireless smoke and heat detectors, 50 wireless translators, 50 wireless output modules and 60 wireless manual call points.

Russian research station «Vostok», the Antarctic



Project size:
100 + devices

Market sector:
science

System type:
wireless

Project description

Vostok Station is a Russian research station in the Antarctic. The station lies at the southern Pole of Cold. The station consists of several buildings including a power station, a meteorology building and living quarters. The station typically contains 25 scientists and engineers.

Reasons for wireless use

Vostok is the coldest place on Earth. In addition to the extremely cold temperatures, other factors make Vostok one of the most difficult places on Earth for human habitation:

- An almost complete lack of moisture in the air.
- A windspeed rising up to 27 metres per second.
- The lack of oxygen
- A higher ionization of the air.

Due to long acclimatization and very short time of installation a wireless system was the obvious solution. At the same time the system should also be very reliable because Vostok station is one of the most isolated established research stations.

Wireless fire system Streletz-PRO is very reliable and an ideal variant for facilities with a number of buildings spread over the site where cables cannot be accommodated.

Manufacturing Plant



Project size:
 – 21,500 m²
 – 1,000 wireless devices

Market sector:
 Industrial facility

System type:
 Wireless

Project description

The project was carried out in 2019 and included the design and installation of fire alarm, notification and evacuation control systems, as well as automatic fire ventilation and fire suppression control systems. The installation was performed by a team of 4 engineers within 10 days at Basfiber basalt fiber plant.

Reasons for wireless use

The primary reasons for choosing the Streletz-PRO wireless system were the system's reliability and the ease and speed of installation process. Thanks to its mesh network, Streletz-PRO offers a higher level of dependability compared to wired systems. Besides, the choice was clearly made in favor of wireless in terms of economic efficiency and quick implementation. Mounting devices in tall production workshops is already a complex undertaking. Yet, laying cable communication lines poses an even bigger challenge. In some places, it's simply unfeasible due to limited access to lifting equipment. Another valuable aspect of the Streletz-PRO is its remote monitoring capability via Streletz-Cloud. The cloud service simplifies connecting to systems and overseeing their technical status.

Residential complex «Academic» in Yekaterinburg



Project size:
 – 100 apartment buildings
 – 18,000 wireless devices

Market sector:
 Apartment buildings

System type:
 Wireless

Project description

«Academic» is the newest and brightest district of the city of Yekaterinburg with a total area of 1.3 thousand hectares. The district is designed for 325 thousand people, and it is planned to build 9 million square meters of residential real estate by 2026. More than 100 residential buildings of the Academic District are protected by Argus Spectrum wireless technology.

Reasons for wireless use

Streletz-PRO is a superb choice for apartment buildings and residential complexes. It offers all the essential features and a diverse range of options to adhere to regulations. This system is adaptable for installation at any construction phase. Concerns about residents inadvertently damaging fire alarm wiring during apartment renovations are nonexistent. The well-known advantages of simple installation and maintenance take on added importance, especially given the scale of these systems, which demand extensive wiring stretching over dozens of kilometers.

Virtual Classroom



Argus Spectrum is very pleased to present its new and unique service for the fire detection world! Web Camera + IP connected kit of actual devices – a leading edge virtual classroom for the programming of Streletz-PRO wireless fire detection system!

The online practical training is simple and easy to use! You will need a desktop or laptop computer and internet access. The online practical training is the perfect way to learn Streletz-PRO. You can study from home or from any place in the world at any time!

The virtual classroom allows fire alarm engineers from all around the world to use one of the remote equipment kits to introduce themselves to the Streletz-PRO wireless alarm system. The user can control and monitor the equipment kit in the Streletz-Master software, while simultaneously observing each device through a live camera feed. The service is completely online, which means that you don't need physical access to a real system in order to learn how to use it.



Streletz-PRO in a virtual classroom



The video tour of the remote equipment kit



200 000 INSTALLATIONS - 9 MILLION WIRELESS DEVICES SOLD!

PROJECTS IN RUSSIA:



Tretyakov Art Gallery, Moscow



Peter the Great Hospital, St.Petersburg

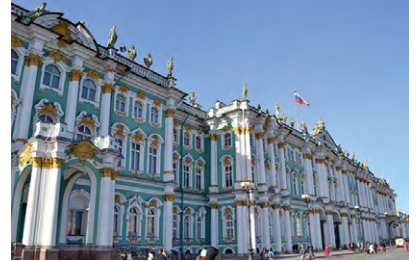

Hermitage, St.Petersburg



Arkhangelskoye Estate Museum, Moscow region



Kursky Railway Station, Moscow



Clinical Hospital of S. S. Yudin, Moscow



Mikhailovsky Theatre, St.Petersburg



Naval Cathedral in Kronstadt



Vnukovo Airport, Moscow



Moscow Clinical Center for Infectious Diseases «Voronovskoye»



Residential complex «Academic», Yekaterinburg



«Four Seasons» Hotel, St.Petersburg

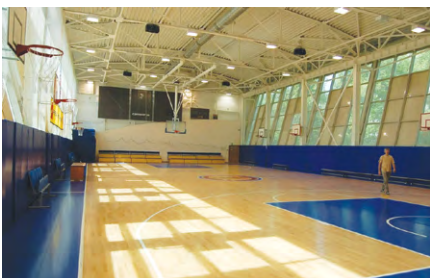

Sports schools, Moscow



Schools and kindergartens, Moscow



Residential complex «Lyuberetskiy», Moscow